

APPARECCHI A MASCHIARE	Art.	BCR	BCRF
TAPPING INSTRUMENTS	Art.	BCR	BCRF
EQUIPAMENTO A ROSCAR A MACHO	Art.	BCR	BCRF

ART. BCR ...

BUSSOLE A CAMBIO RAPIDO
QUICK CHANGE ADAPTORS
BUJE DE CAMBIO RÁPIDO

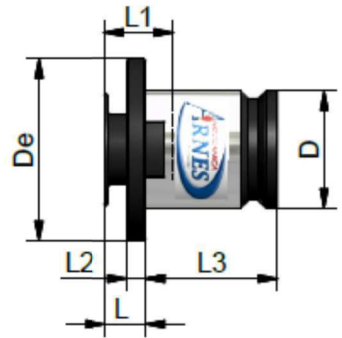

ART	Campo di filettatura For Taps	Diametro del gambo maschio Shank dia. (d)	Per mandrini grandezza Suitable for chucks size	De ø	D ø	L1	L2	L3	L
BCR 0	M 1 – M 10	2,5 – 8	0	22	13	15	4	19,5	7
* BCR 1	M 3 – M 12	3,5 – 11,3	1	30	19	17	4	21,5	7
* BCR 2	M 8 – M 20	7 – 18	2	48	31	30	5	35	11
* BCR 3	M 14 – M 33	11 - 28	3	70	48	44	6	55,5	14

* Adatta anche per passaggio centrale del refrigerante
 * Also suitable for coolant flow

ART. BCRF ...

BUSSOLE A CAMBIO RAPIDO CON FRIZIONE DI SICUREZZA
QUICK CHANGE ADAPTORS WITH SAFETY CLUTCH
BUJE DE CAMBIO RÁPIDO CON LA EMBRAGUE DE SEGURIDAD

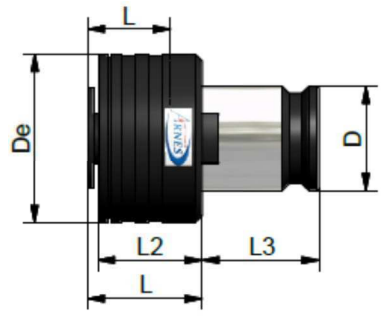

ART	Campo di filettatura For Taps	Diametro del gambo maschio Shank dia. (d)	Per mandrini grandezza Suitable for chucks size	De ø	D ø	L1	L2	L3	L
BCR F0	M 1 – M 10	2,5 – 8	0	23	13	15	20	19,5	21
* BCR F1	M 3 – M 12	3,5 – 11,3	1	32	19	17	25	21,5	25
* BCR F2	M 8 – M 20	7 – 18	2	50	31	30	31	35	34
* BCR F3	M 14 – M 33	11 - 28	3	72	48	44	41	55,5	45

* Adatta anche per passaggio centrale del refrigerante
 * Also suitable for coolant flow

APPARECCHI A MASCHIARE

Art. BFCR

TAPPING INSTRUMENTS

Art. BFCR

EQUIPAMENTO A ROSCAR A MACHO

Art. BFCR

ART. BFCR ...

BUSSOLE A CAMBIO RAPIDO PER FILIERE

QUICK CHANGE ADAPTORS FOR DIES

BUJE DE CAMBIO RÁPIDO PARA TERRAJA

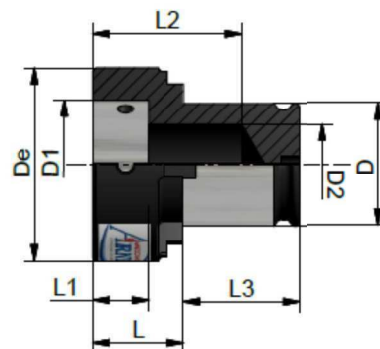

ART	Metrica Metric	Filettatura Thread Metrica fine Fine Metric	Whitworth	Whitworth G ...	Per mandrini grandezza Suitable for chucks size	De Ø	D1 Ø	D Ø	D2 Ø	L1	L2	L3	L
BFCR 1 FIL 16x5	M1-M2,6	M1-M2,6	-	-	1	25	16	19	12,5	4,8	28	21,5	14
BFCR 1 FIL 20x5	M3-M4	M3-M6	-	-	1	30	20	19	12,5	4,8	28	21,5	14
BFCR 1 FIL 20x7	M5+M6	-	1/4"	-	1	30	20	19	12,5	6,5	30	21,5	16
BFCR 1 FIL 25x9	M7-M9	M7-M9	5/16"	-	1	35	25	19	12,5	8,5	33	21,5	19
BFCR 1 FIL 30x11	M10+M1 1	M10+M11	3/8"+7/ 16"	-	1	40	30	19	12,5	10	35	21,5	21
BFCR 1 FIL 38x10	-	M12-M15	-	G1/8"+G1 /4"	1	48	38	19	14,2	9	34	21,5	20
BFCR 1 FIL 38x14	M12+M1 4	-	1/2"	-	1	48	38	19	14,2	13	38	21,5	24
BFCR 2 FIL 20x5	M3-M4	M3-M6	-	-	2	30	20	31	22	4,8	55	35	20
BFCR 2 FIL 20x7	M5+M6	-	1/4"	-	2	30	20	31	22	6,5	56	35	21,5
BFCR 2 FIL 25x9	M7-M9	M7-M9	5/16"	-	2	35	25	31	22	8,5	55	35	23,5
BFCR 2 FIL 30x11	M10+M1 1	M10+M11	3/8"+7/ 16"	-	2	40	30	31	22	10	57	35	22
BFCR 2 FIL 38x10	-	M12-M15	-	G1/8"+G1 /4"	2	48	38	31	22	9	56	35	21
BFCR 2 FIL 38x14	M12+M1 4	-	1/2"	-	2	48	38	31	22	13	60	35	25
BFCR 2 FIL 45x14	-	M16-M20	-	G3/8"+G1 /2"	2	57	45	31	22	13	60	35	25
BFCR 2 FIL 45x18	M16- M20	-	5/8"+3/ 4"	-	2	57	45	31	22	17	64	35	29

ART. BFCR ...

BUSSOLE A CAMBIO RAPIDO PER FILIERE
QUICK CHANGE ADAPTORS FOR DIES
BUJE DE CAMBIO RÁPIDO PARA TERRAJA

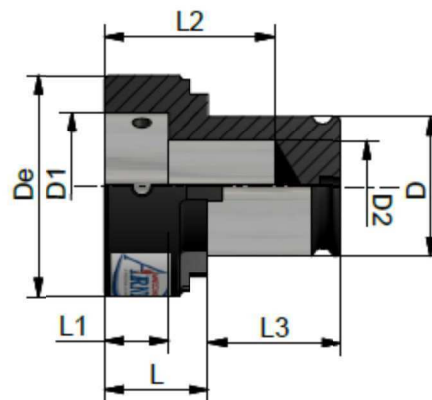

ART	Campo di filettatura		Diametro del gambo maschio	Per mandrini grandezza	De ∅	D ∅	L1	L2	L3	L			
	For Taps		Shank dia. (d)	Suitable for chucks size									
BFCR 3 FIL 30x11	M10+M1 1	M10+M1 1	3/8"+7/16"	-	3	60	30	48	25	10	85	55,5	30
BFCR 3 FIL 38x10	-	M12- M15	-	G1/8"+G1/4"	3	60	38	48	32	9	83	55,5	28
BFCR 3 FIL 38x14	M12+M1 4	-	1/2"	-	3	60	38	48	32	13	87	55,5	32
BFCR 3 FIL 45x14	-	M16- M20	-	G3/8"+G1/2"	3	60	45	48	37	13	87	55,5	32
BFCR 3 FIL 45x18	M18+M2 0	-	5/8"+3/4"	-	3	60	45	48	37	17	91	55,5	36
BFCR 3 FIL 55x16	-	M21- M26	-	G5/8"	3	72	55	48	37	15	85	55,5	30
BFCR 3 FIL 55x22	M22+M2 4	-	7/8"+1"	-	3	72	55	48	37	20	90	55,5	35
BFCR 3 FIL 65x18	-	M27- M36	-	G3/4"+G1	3	82	65	48	37	17	87	55,5	32
BFCR 3 FIL 65x25	M27- M36	-	1.1/8"+ 1.3/8"	-	3	82	65	48	37	23	93	55,5	38

APPARECCHI A MASCHIARE	Art.	BRC
TAPPING INSTRUMENTS	Art.	BRC
EQUIPAMENTO A ROSCAR A MACHO	Art.	BRC

ART. BRC ...

BUSSOLE RIDUZIONE A CAMBIO RAPIDO
REDUCTION FROM ADAPTER TO ADAPTER
BUJE DE CAMBIO RÁPIDO PARA TERRAJA

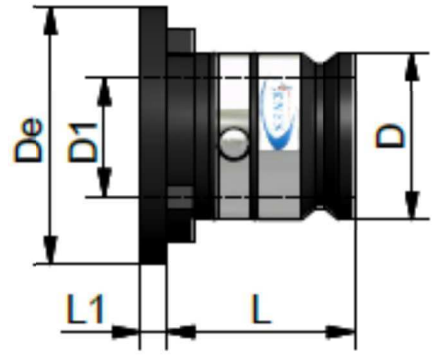

ART	D Ø	D1 Ø	De Ø	L	L1
BRC 2/1	31	19	48	35	5
BRC 3/2	48	31	70	55,5	6

APPARECCHI A MASCHIARE	Art.	TPO
TAPPING INSTRUMENTS	Art.	TPO
PORTA MACHO E TERRAJA PARA TORNO	Art.	TPO

PORTA MASCHI E FILIERE PER TORNIO PARALLELO
TAPPING MACHIN FOR PARALLEL LATHE

ART. TPO B18

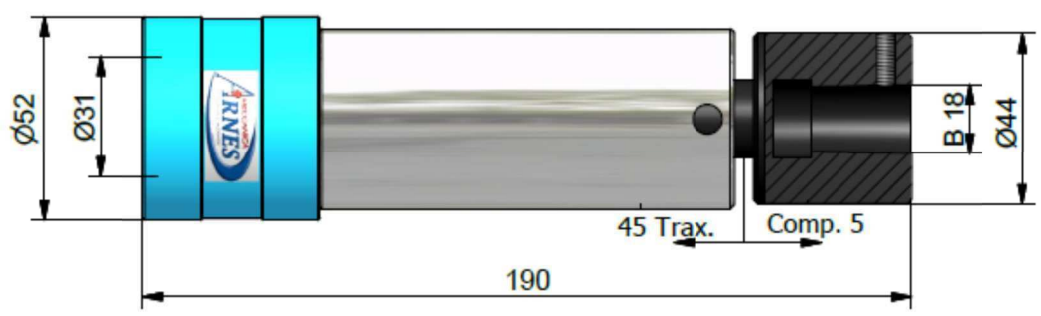
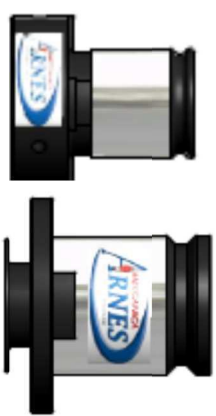

ART	Campo filettatura For Taps	Per bussole For adaptors size	Compensazione assiale Length compensation	
			Traz. Exp.	Comp. Press.
TPO 320 B18	M 3 – M 20	2 (2/1)	45	5

ART. ISO 15



ISO 15

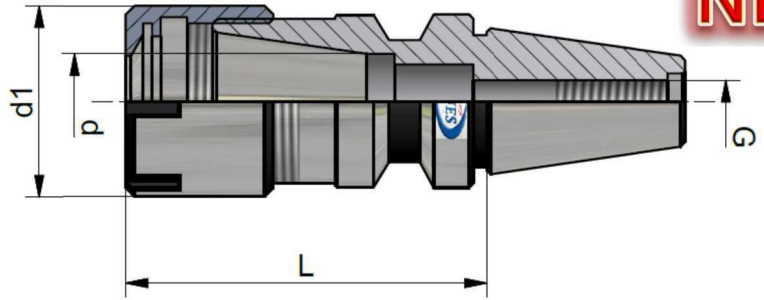

NEW

ART	K	d	d ₁	L	Pinze Pincers	G
ISO15P0/1511	ISO 15	1 - 7	16	40	ER 11	M 6
ISO15P0/1516		1 - 10	22	40	ER 16	



CODOLO ISO 15

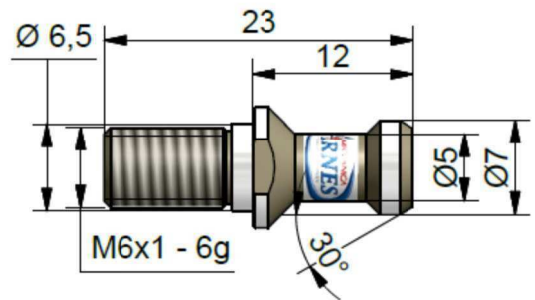

ART. ISO 20



ISO 20

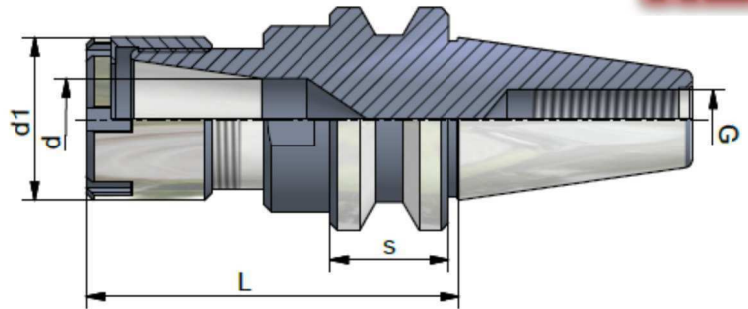

NEW

ART	K	d	d ₁	L	S	Pinze Pincers	G
ISO20P0/2016	ISO 20	1 - 10	16	50	15,9	ER 16	M 8
ISO20P0/2020		1 - 13	22	55	15,9	ER 20	



CODOLO ISO 20

